



CLEANSOURCE® HD675 UPS



40 %
TCO Savings



12 x
Less likely to fail



9 x
Less carbon emissions

60Hz | 675 kW | 480V | Flywheel Technology

CLEANSOURCE® HD675 UPS

Overview

Active Power's CLEANSOURCE® HD675 delivers 40% TCO savings, is 12 times less likely to fail, and reduces your impact on the environment by 90%. Based on a field-proven design, our flywheel UPS is a perfect fit for today's mission critical applications in data centers, health care facilities, and industrial and manufacturing sites.

Parallel Online Architecture

The CLEANSOURCE® HD675 is rated at 750 kVA / 675 kW. Up to 7 UPS systems can be paralleled for redundancy or capacity, supporting over 4.725 MW of backup power in a single paralleled system.

Active Power's Parallel Online Architecture provides excellent isolation between input and output, while delivering a clean sinusoidal waveform to critical loads. CLEANSOURCE® HD675 UPS is able to protect against all 9 IEEE power disturbances, such as voltage fluctuations, harmonics and complete power outage.

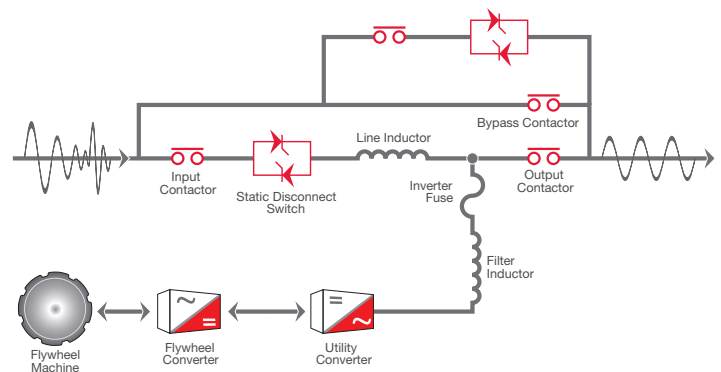

Flywheel Technology

- ✓ Stores 10.5 MJ of energy
- ✓ Up to 1 minute of runtime (load dependent)
- ✓ Wide ambient temperature range – 0°C to 40°C
- ✓ High density, high efficiency design

Key Benefits and Features

- ✓ Up to 98% efficient
- ✓ Half the space of legacy battery based UPS
- ✓ Lower installation costs
- ✓ Less heat rejection
- ✓ Lower cooling requirements
- ✓ Lower maintenance and service
- ✓ Cost-effective installation
- ✓ Generator compatibility
- ✓ 20-year design life

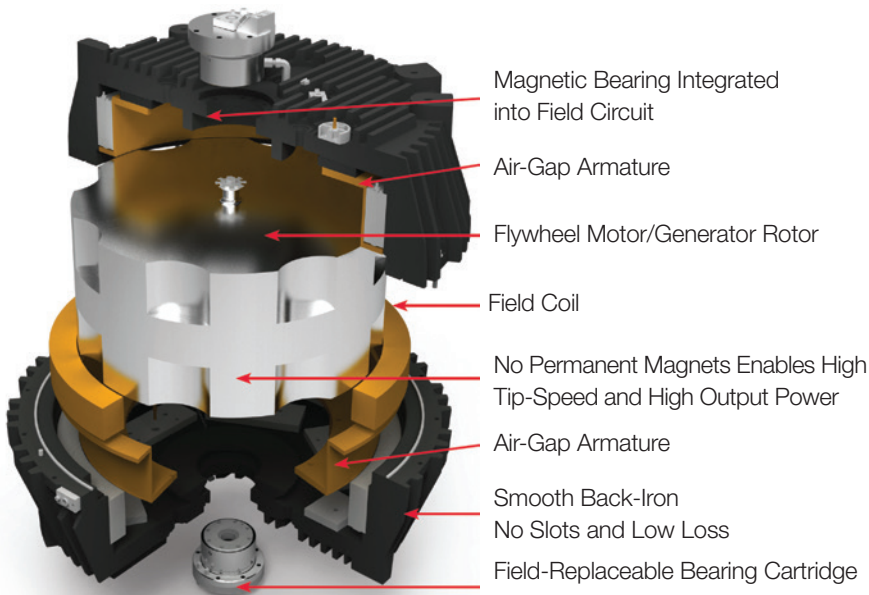

High density, high efficiency design

Service and Maintenance

Active Power has designed the CLEANSOURCE® HD675 with ease of maintenance in mind to ensure your critical power infrastructure operates with the utmost reliability.

CLEANSOURCE® HD675 requires one simple and non-invasive annual maintenance.

A streamlined maintenance schedule both restores your UPS to factory-like condition and reduces downtime during its operating life, thereby improving the availability of your operation.

40% TCO Savings

CLEANSOURCE® HD675 combines a competitive initial cost with lower ongoing operational expense – up to 40% lower than traditional UPS over 15 years. The result is a dramatic TCO benefit for your application, with net savings to you from day 1 of operation.

- ✓ Superior energy efficiency – over 96% efficient at 40% load
- ✓ Lower maintenance requirements – routine annual check-up and bearing change every third year
- ✓ Reduced cooling needs – no need for dedicated cooling for batteries
- ✓ No battery changes – integrated flywheel with 20 year life

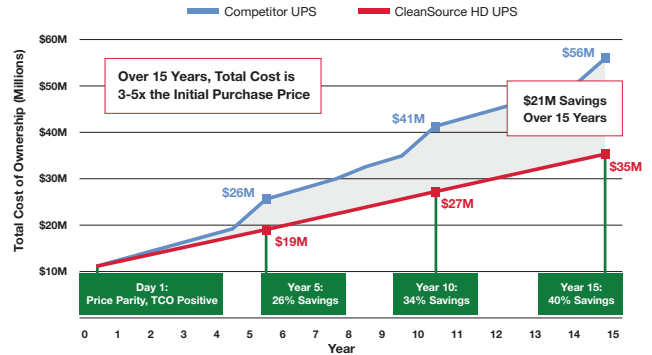

12x Less Likely to Fail

Proven to be 12 times less likely to fail than a battery based system, the integrated flywheel energy storage of the CLEANSOURCE® HD675 UPS makes it inherently reliable, delivering predictable, consistent back up power. The flywheel is constantly spinning, storing kinetic energy and ready to assume the load in case of a power outage. By contrast, battery failures are the leading cause of UPS load loss and system downtime.

“With a dynamic electromechanical system like CLEANSOURCE® HD, demand failures are highly unlikely. With the flywheel spinning, any changed affecting system health are detected and repairable prior to an outage occurring. Conversely, a battery based system is an electrochemical process and exhibits non-detectable failures even with monitoring and routine maintenance.”

Steve Fairfax | President, MTechnology, Inc.

9x Less Carbon Emissions

CLEANSOURCE® HD675 UPS is the smart and responsible choice for the environment, saving thousands of tons of carbon from being emitted. The integrated flywheel permanent energy storage uses up to 90% less embedded carbon to manufacture versus lead-acid batteries. CLEANSOURCE® UPS high efficiency and lower cooling requirements contribute to lower power consumption and reducing operational carbon emissions by 40% over the life the product. In comparison to lead-acid batteries, flywheels last up to 20 years, are not toxic, take up 50% less space and require less maintenance.



60Hz | 675 kW | 480V

Product Specifications CLEANSource® HD675 UPS

RATING		
Maximum kVA	750	
Maximum kW	675	
OUTPUT		
Voltage	480 VAC 3-phase, 3-wire plus ground	
Voltage regulation	Steady state	+/-1 % for +/-10 % input
	Flywheel mode	+/-1 % steady state
	Transient	+/-1 % within 50 mSec for 100 % load step
Voltage distortion ¹	<1% linear loads and <5% for 100% non-linear loads	
Inverter	PWM with IGBT switching	
Frequency	60Hz (mains synchronized) (normal operation +/- 0.2 % free running)	
Load Power Factor Range	0.7 lagging / 0.9 leading without derating	
Slew Rate	Adjustable from 0.2Hz/second to 3.0Hz/second	
Current - Nominal (480 VAC)	903A	
Overload Capability-Mains Operation	Cont.:	105%
	10 min:	<110%
	5 min:	<125%
	1 min:	<150%
	10s:	<200%
Immediate:	>200%	
UPS Efficiency ²	96.5% @ 50% load up to 98% @ 100% load	
INPUT		
Voltage ³	480 VAC 3-phase, 3-wire plus ground	
Voltage Range	+10% / -15% (programmable)	
Frequency	60 Hz +/- 10% maximum (programmable) +/- 3% (default)	
Power Factor	0.99 at rated load and nominal voltage	
Harmonic Current Distortion	Linear Load	<2% at 100% load
	Non-Linear Load ⁴	<5% at 100% load
Current - Nominal (480 VAC)	846A	
Current - Maximum	1050A	
Surge Withstand	Meets IEEE 587/ANSI C62.41	
Walk-In	1 to 15 seconds (programmable)	
Internal Backfeed Protection	Yes	
ENERGY STORAGE		
Type	Integrated Steel Flywheel spinning at 7,700 RPM	
Flywheel Runtime (% Load)	100%:	15s
	75%:	20s
	50%:	29s
	25%:	59s
Flywheel Recharge Time	< 2 min (nominal) at 175kW 3 min (programmable) at 100kW	

¹ EN 62040-3

² DC energy storage offline

³ From grounded wye source

⁴ Design per UL891

⁵ 100% load (675kW)

GENERAL DATA		
Parallel Capability	Yes, up to 7 systems = 4.725MW	
Internal Static Bypass	Included	
Control Panel	10-inch Color Touchscreen Graphical Display	
Withstand Capability ⁴	65kA	
Remote Monitoring	Yes (optional)	
External Customer Contacts	8 Input and 8 Outputs (programmable)	
ENVIRONMENTAL		
Audible Noise	<83 dBA at 1 meter	
Temperature	Operating	32 to 104° F (0 to 40°C)
	Storage	-13 to 158° F (-25 to 70°C)
Humidity	5% to 95% (non-condensing)	
Altitude ⁴	Up to 3,000 feet (914 meter) 1.2°C derating for every 1000ft above 3000ft	
Emissions and Immunity	FCC Class A, Subpart J of Part 15/ EN 62040-2	
Heat Rejection - Online ⁵	19.10kW / 65,210 BTU/h	
PHYSICAL DATA		
Height	80 in (2,032 mm)	
Width	132 in (3,353 mm)	
Depth	39 in (991 mm)	
Weight	10,971 lbs (4,976 kg)	
Cable Entry	Top or Bottom	
Safety	UL 1778 listed. CUL CAN/CSA 22.2 No. 107.1	

ADDITIONAL OPTIONS	
4-wire Input	
Dual Input	
High Resistance Ground (HRG)	
Remote SNMP / MODBUS Monitoring	
CSView - Real-time Monitoring	
GenSTART - Generator Start Power	
Remote EPO	
Floorstand Kit	
Remote Status Panel	
SYSTEM FEATURES	
Online and Fault-Tolerant UPS	
Predictable Flywheel Energy Storage	
20-year Design Life	
Wide Operating Temperature Range	
Quick Recharge Time	
Low Maintenance and Service	
Comprehensive Service and Support	
Multi-vendor Generator and Switchgear Compatibility	
Simple and Cost Effective Installation	
No Hazardous Waste Material	
Field Proven Reliability	



Active Power Inc. is part of the Piller Power Group

activepower.com

ACTIVE POWER INC., AUSTIN, TEXAS.

Piller Australia | Piller China | Piller France | Piller Germany | Piller India | Piller Italy | Piller Singapore | Piller Spain | Piller UK | Piller USA



A Langley Holdings Company